



NEMO EVALUATION REPORT (NER)



WAUSAU TILE

Wausau Tile, Inc.

PO Box 1520

Wausau, WI 54401-1520

(800) 562-2728

SUBJECT: Wausau Pedestal/Paver Systems over Aussie Membrane Waterproofing Systems

SCOPE: This NEMO Evaluation Report (henceforth 'NER') is issued under F.A.C. Rule 61G20-3 and the applicable rules and regulations governing Product Approval of construction materials in the State of Florida and ISO/IEC 17065 via NEMO|cert. NEMO Evaluations has evaluated the product described herein for compliance with the Code sections noted herein.

CODE: 2023 Florida Building Code, 8th Edition

JURISDICTION: Non-HVHZ and HVHZ

NEMO CATEGORY: Flooring

FBC CATEGORY: Roofing

FBC SUB-CATEGORY: Roofing Accessories that are an Integral Part of the Roofing System

CSI DIVISION: N/A

METHOD: Method 1, Option C – Codified Material, Evaluation by Evaluation Entity

COMPLIANCE STATEMENT: Wausau Pedestal/Paver Systems, as produced by Wausau Tile, Inc., have demonstrated compliance with the Code sections noted herein through testing in accordance with the referenced Standards, rational analysis and an ongoing quality assurance program. Compliance is subject to the Installation Requirements and Limitations of Use set forth herein.

QUALITY ASSURANCE: Evidence of current quality assurance shall be listing and labeling in accordance with the requirements of NEMO|cert.

PACKAGING AND IDENTIFICATION: Reference is made to FBC 3115.2.5

CONTINUED COMPLIANCE: This NER is valid until such time the named product(s) change, the referenced Quality Assurance changes, or the evaluated Code provisions change. NEMO Evaluations requires, at minimum, a complete review of this NER with each 3-year Code Cycle.

BUILDING PERMIT REQUIREMENTS: As required by the Building Official or Authority Having Jurisdiction to evaluate the installation of this product.

ADVERTISEMENT: "NEMO Evaluated" may be displayed in advertising literature. If any portion of the NER is displayed, it shall be displayed in its entirety.

CERTIFICATION OF INDEPENDENCE:
- NEMO CERT, LLC does not have, nor does it intend to acquire or will it acquire, a financial interest in any company manufacturing or distributing products it evaluates.
- NEMO CERT, LLC is not owned, operated or controlled by any company manufacturing or distributing products it evaluates.
- This is a building code evaluation. NEMO CERT, LLC is not, in any way, the Designer of Record for any project on which this NER, or previous versions thereof, is/was used for permitting or design guidance.



1. CODES, PROPERTIES AND STANDARDS:

CODE	SECTION	PROPERTY	STANDARD
2023 Florida Building Code, 8 th Edition	3115.1.1	Attached Exterior Elevated Flooring Systems	
	3115.2.4 / 2615.2	Tensile Properties	ASTM D638
	3115.2.4 / 2615.2	Accelerated Weathering	ASTM G155
	M-D Checklist #0445	Rate of Burning	ASTM D635
	M-D Checklist #0445	Self-Ignition Temperature	ASTM D1929
	M-D Checklist #0445	Density of Smoke	ASTM D2843
	TAS 110	Wind resistance	TAS 114, Appendix D

2. PRODUCTS:

TABLE 1: EVALUATED COMPONENTS (UNDER NEMO QA/SURVEILLANCE) ¹

WAUSAU HIDDEN LOK-DOWN SYSTEM FOR WIND UPLIFT, CONSISTING OF:

TRADE NAME	DESCRIPTION
Wausau Paver	Min. 7,000 psi concrete walking pavers designed with a kerf at corners and/or edges to receive washer from the Hidden Lok-Down Hardware, available as H-Series or V-Series.
Wausau IPE Paver	Wood walking pavers designed with a kerf at corners and/or edges to receive washer from the Hidden Lok-Down Hardware
3M™ Scotch-Weld™ Pedestal Adhesive	Adhesive for use to bond Terra Stand Pedestal base to waterproofing top surface.

1. Terra-Stand Core		
2. Terra-Stand Base		
3. Terra-Stand Top		
4. Lock Washer		
5. Anchor Nut		
6. Threaded Insert		
7. Bolt		
8. S/S Washer (2.5" diameter)		
9. Terra-Tab		

¹ Contact contact@nemocert.com for production location(s) of non-Certified products covered by QA/Surveillance services.



TABLE 1: EVALUATED COMPONENTS (UNDER NEMO QA/SURVEILLANCE) ²



WAUSAU TERRA-GRID SYSTEM, CONSISTING OF:	
TRADE NAME	DESCRIPTION
Wausau Paver	Min. 7,000 psi concrete walking pavers, available as H-Series, V-Series or Thin Series.
Wausau Terra-Grid	Molded fiberglass / polyester resin grate designed to be secured to the Terra-Stand with a Terra-Grid Cube and bolt
3M™ Scotch-Weld™ Pedestal Adhesive	Adhesive for use to bond Terra Stand Pedestal base to waterproofing top surface and exterior tile or paver to Terra-Grid top surface.
1. Terra-Stand Core	
2. Terra-Stand Base	
3. Terra-Stand Top	
4. Terra-Cube with Puck Unit	
5. S/S Anchor Bolt	
6. Nut, Lock Washer & Threaded Insert	
	

TABLE 2: COMPONENTS BY OTHERS (4.1.3)

TYPE	PRODUCT	By	FBC	NOA
MEMBRANE (LIQUID-APPLIED):	Aussie Membrane 570	AVM Industries	N/A	22-0929.01
	Aussie Membrane 520 PRO	AVM Industries	N/A	22-0722.05
REINFORCEMENT:	Mat 570	AVM Industries	N/A	22-0929.01
PRIMERS:	AVM Primer 570-SB	AVM Industries	N/A	22-0929.01
PROTECTION SHEET:	AVM 570 Protection Sheet	AVM Industries	N/A	22-0929.01
INSULATION:	Styrofoam Highload 60	DuPont de Nemours	FL38732	23-1121.01
ADHESIVE:	Millennium One Step Foamable Adhesive	H.B. Fuller	FL1800	21-1018.06

² Contact contact@nemocert.com for production location(s) of non-Certified products covered by QA/Surveillance services.

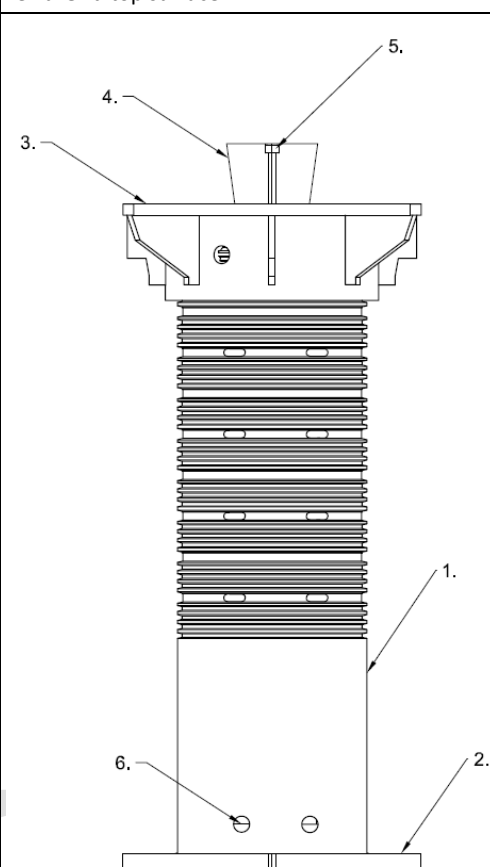

3. INSTALLATION:

3.1 Wausau Pedestal/Paver Systems over Aussie Membrane 570 Waterproofing Systems shall be installed in accordance with Wausau Tile, Inc. published installation instructions, subject to the Limitations of Use noted herein and specifics noted below.

3.1.1 Wausau As-Tested Specifics:

(a) Unless otherwise noted, the Terra-Stand base is fully adhered to the waterproofing top-surface using 3M™ Scotch-Weld™ Pedestal Adhesive DP6330NS applied at 1.35 fl. oz. per base.



(b) Unless otherwise noted, Wausau Pavers are partially adhered atop Terra-Grid using 3M™ Scotch-Weld™ Pedestal Adhesive DP6330NS ribbons applied max. 3-inch o.c. (every-other-grid-edge).



3.1.2 Insulation Adhesive:

(a) Unless otherwise noted, insulation adhesive application rates are as follows.

Ribbons shall be applied and insulation boards shall be set in accordance with the manufacturer’s published instructions. When multiple layers(s) of insulation and/or coverboard are installed in ribbon-applied adhesive, boards shall be staggered. The maximum edge distance from the adhesive ribbon to the edge of the insulation board shall be not less than one-half the specified ribbons spacing.

INSULATION ADHESIVE REFERENCES		
ADHESIVE	REFERENCE	RATE
Millennium One Step Foamable Adhesive	OSFA	Continuous ribbons, 12-inch o.c.

(b) Unless otherwise noted, all insulations are flat-stock or taper board of the minimum thickness noted.

3.1.2 Waterproofing:

(a) Waterproofing shall be installed in accordance with the requirements of the waterproofing manufacturer and the associated Florida Product Approval or NOA, subject to the limitations herein.

(b) Unless otherwise noted, refer to the following for application rates.



WATERPROOFING APPLICATIONS						
REFERENCE	LAYER	MATERIAL	APPLICATION			
			BASE COAT	REINFORCEMENT	TOP COAT	PROTECTION
Aussie Membrane 520 PRO Waterproofing System	Waterproofing	Polyurethane waterproofing membrane	None	None	AVM 520 PRO at 90-mils	None
Aussie Membrane 570 Waterproofing System	Waterproofing	Rubberized asphalt waterproofing membrane with reinforcement	AVM 570 hot rubber at 90-mils	AVM Mat 570 into wet base coat	AVM 570 hot rubber at 115-mils	AVM 570 Protection Sheet into wet top coat

- (c) Bearing capacity and drainage of the waterproofing system shall comply with [FBC 3115.5](#).
- (d) The Authority Having Jurisdiction may require integrity flood testing (ASTM D5957) or Electric Field Vector Mapping tests of all waterproofing systems prior to placement of overburden materials. Testing, if required by the Authority Having Jurisdiction, should be conducted by a qualified testing agency or professional.

4. LIMITATIONS OF USE:

4.1 General:

- 4.1.1 This is a building code evaluation. NEMO CERT, LLC is not, in any way, the Designer of Record for any project on which this NER, or previous versions thereof, is/was used for permitting or design guidance. NERs are not to be construed as representing any attributes not specifically listed, nor are NERs to be construed as an endorsement of the subject of the report or a recommendation for its use. There is no warranty by NEMO CERT, LLC, express or implied, as to any finding or other matter in this report, or as to any product covered by the report.
- 4.1.2 This NER pertains to paver/pedestal overburden components as an Attached Exterior Elevated Flooring System per [FBC 3115.1.1](#).
 - (a) Structural members and roof decks shall be in accordance with FBC requirements to the satisfaction of the Authority Having Jurisdiction.
- 4.1.3 All components in the assembly shall have quality assurance surveillance in accordance with **F.A.C. Rule 61G20-3**. For components listed herein that are produced by a manufacturer other than the report holder on [Page 1](#) of this NER, refer to the [Florida Product Approval](#) or [NOA](#) of the component manufacturer.

4.2 Jurisdiction Specific:

	Non-HVHZ	HVHZ
4.2.1	This NER does not include evaluation of fire classification. Refer to FBC 1505 and the fire classification certificate for the waterproofing manufacturer for requirements and limitations regarding roof assembly fire classification. Refer to FBC 2603 for requirements and limitations concerning the use of foam plastic insulation.	This NER does not include evaluation of fire classification. Refer to FBC HVHZ 1516 and the fire classification certificate for the roof cover manufacturer for requirements and limitations regarding roof assembly fire classification. Refer to FBC 2603 for requirements and limitations concerning the use of foam plastic insulation.
4.2.2	This NER does not include evaluation of roof edge termination. Refer to FBC 1504.5 for requirements and limitations regarding edge securement for low-slope roofs.	This NER does not include evaluation of roof edge termination. Refer to RAS 111 for requirements and limitations regarding edge securement for low-slope roofs.
4.2.3	Refer to FBC 1511 for requirements and limitations regarding recover installations.	Refer to FBC HVHZ 1521 for requirements and limitations regarding recover installations.
(a) RESERVED		RESERVED



(b) For adhered re-roof (tear off) installation, the existing substrate shall be examined for compatibility with the adhesive. If any surface conditions exist that bring system performance into question, field uplift testing in accordance with [ANSI/SPRI IA-1](#), [FM Loss Prevention Data Sheet 1-52](#) or [TAS 124](#) shall be conducted on mock-ups of the proposed interface.

(c) RESERVED

4.2.4 Wind Load Resistance:

(a) Refer to [Section 4.3](#) for a tabulated summary of assembly listings and maximum allowable design pressures.

(b) "MDP" = Maximum Design Pressure is the result of testing for wind load resistance based on allowable wind loads, and reflects the ultimate passing pressure divided by 2 (*the 2 to 1 margin of safety per [FBC 1504.9](#) has already been applied*). Refer to [FBC 1609](#) for determination of design wind loads.

(c) RESERVED

(d) For fully-adhered installations, the maximum design pressure for the selected assembly shall meet or exceed the critical design pressure. Rational analysis is not permitted.

For adhered re-roof (tear off) installation, the existing substrate shall be examined for compatibility with the adhesive to be installed. If any surface conditions exist that bring system performance into question, field uplift testing in accordance with [TAS 124](#) shall be conducted on mock-ups of the proposed interface.

RESERVED

"MDP" = Maximum Design Pressure is the result of testing for wind load resistance based on allowable wind loads, and reflects the ultimate passing pressure divided by 2 (*the 2 to 1 margin of safety per [TAS 114](#) has already been applied*). Refer to [FBC HVHZ 1620](#) or [RAS 128](#) for determination of design wind loads.

RESERVED

The maximum design pressure (MDP) limitation shall be applicable to all roof pressure zones. Rational analysis is not permitted.





4.3 System Listings and Allowable Design Pressures: See [Section 4.2.4](#)

TABLE 2: STRUCTURAL CONCRETE DECKS – NEW CONSTRUCTION OR REROOF (TEAR-OFF)									
SYSTEM TYPE A-2: BONDED WATERPROOFING, BONDED INSULATION, ATTACHED EXTERIOR ELEVATED FLOORING SYSTEM									
System No.	Deck (4.1.2)	Primer	Waterproofing (3.1.2)			Insulation		Attached Exterior Elevated Flooring System per FBC 3115.1.1	MDP (psf)*
			Base Ply	Ply	Cap Ply	Type	Attach (3.1.2)		
AUSSIE MEMBRANE 520 PRO WATERPROOFING SYSTEM									
C-1.	Structural concrete	None	None	None	Aussie Membrane 520 PRO Waterproofing System	Min. 2-inch, Styrofoam Highload 60	OSFA, 6-inch o.c.	Wausau Hidden Lok-Down, Hidden Lok-Down IPE or Terra-Grid System installed in a max. 2 x 2 ft grid pattern in accordance with Wausau Tile, Inc. requirements. Terra-Stand base is fully adhered to the waterproofing top-surface using 3M™ Scotch-Weld™ Pedestal Adhesive DP6330NS applied at 1.35 fl. oz. per base (See 3.1.1) .	-237.5
AUSSIE MEMBRANE 570 WATERPROOFING SYSTEM									
C-2.	Structural concrete	AVM Primer 570-SB, 400 ft ² /gal	None	None	Aussie Membrane 570 Waterproofing System	Min. 2-inch, Styrofoam Highload 60	OSFA, 6-inch o.c.	Wausau Hidden Lok-Down, Hidden Lok-Down IPE or Terra-Grid System installed in a max. 2 x 2 ft grid pattern in accordance with Wausau Tile, Inc. requirements. Terra-Stand base is fully adhered to the waterproofing top-surface using 3M™ Scotch-Weld™ Pedestal Adhesive DP6330NS applied at 1.35 fl. oz. per base (See 3.1.1) .	-235.0

TABLE 3: STRUCTURAL CONCRETE DECKS – NEW CONSTRUCTION OR REROOF (TEAR-OFF)									
SYSTEM TYPE F: NON-INSULATED, BONDED WATERPROOFING, ATTACHED EXTERIOR ELEVATED FLOORING SYSTEM									
System No.	Deck (4.1.2)	Primer	Waterproofing (3.1.2)			Attached Exterior Elevated Flooring System per FBC 3115.1.1	MDP (psf)*		
			Base Ply	Ply	Cap Ply				
AUSSIE MEMBRANE 520 PRO WATERPROOFING SYSTEM									
C-3.	Structural concrete	None	None	None	Aussie Membrane 520 PRO Waterproofing System	Wausau Hidden Lok-Down, Hidden Lok-Down IPE or Terra-Grid System installed in a max. 2 x 2 ft grid pattern in accordance with Wausau Tile, Inc. requirements. Terra-Stand base is fully adhered to the waterproofing top-surface using 3M™ Scotch-Weld™ Pedestal Adhesive DP6330NS applied at 1.35 fl. oz. per base (See 3.1.1) .	-227.5		
AUSSIE MEMBRANE 570 WATERPROOFING SYSTEM									
C-4.	Structural concrete	AVM Primer 570-SB, 400 ft ² /gal	None	None	Aussie Membrane 570 Waterproofing System	Wausau Hidden Lok-Down, Hidden Lok-Down IPE or Terra-Grid System installed in a max. 2 x 2 ft grid pattern in accordance with Wausau Tile, Inc. requirements. Terra-Stand base is fully adhered to the waterproofing top-surface using 3M™ Scotch-Weld™ Pedestal Adhesive DP6330NS applied at 1.35 fl. oz. per base (See 3.1.1) .	-150.0		