



NEMO EVALUATIONS REPORT

Report No.: NER-MCI-001.R3
Revision 3: 2026-02-12
Page 1 of 7

Marco Industries
FL46865-R3

Nemo|cert.
353 Christian Street, Unit 12b
Oxford, CT 06478
(475) 888-CERT (2378)
www.nemocert.com

INSPECT

CERTIFY

EVALUATE

VALIDATE

QUALIFY

NEMO EVALUATION REPORT (NER)



Marco Industries, Inc.
4150 S 100th E. Ave.
Tulsa, OK 74145
(800) 800-8590

SUBJECT: Marco Roof Vents

SCOPE: This NEMO Evaluation Report (henceforth 'NER') is issued under F.A.C. [Rule 61G20-3](#) and the applicable rules and regulations governing Product Approval of construction materials in the State of Florida and ISO/IEC 17065 via [NEMO|cert.](#) NEMO Evaluations has evaluated the product described herein for compliance with intent of the [Code sections noted herein](#).

CODE: 2023 Florida Building Code, 8th Edition

JURISDICTION: Non-HVHZ and HVHZ

NEMO CATEGORY: Pre-Assembled Systems

FBC CATEGORY: Roofing

FBC SUB-CATEGORY: Roofing Accessories that are an Integral Part of the Roofing System

CSI DIVISION: 07 00 00 Thermal and Moisture Protection
07 72 00 Roof Accessories
07 72 26 Ridge Vents

METHOD: Method 1, Option C – Codified Material, Evaluation by Evaluation Entity

COMPLIANCE STATEMENT: **Marco Roof Vents**, as produced by **Marco Industries**, has demonstrated compliance with the intent of the [Code sections noted herein](#) through testing in accordance with the referenced Standards, rational analysis and an ongoing quality assurance program. Compliance is subject to the [Installation Requirements](#) and [Limitations of Use](#) set forth herein.

QUALITY ASSURANCE: Evidence of current quality assurance shall be listing and/or labeling in accordance with the requirements of [NEMO|cert.](#)

CONTINUED COMPLIANCE: This NER is valid until such time the named product(s) change, the referenced Quality Assurance changes, or the evaluated Code provisions change. NEMO Evaluations require, at minimum, a complete review of this NER with each 3-year Code Cycle.

BUILDING PERMIT REQUIREMENTS: As required by the Building Official or Authority Having Jurisdiction to evaluate the installation of this product.

ADVERTISEMENT: "NEMO Evaluated" may be displayed in advertising literature. If any portion of the NER is displayed, it shall be displayed in its entirety.

CERTIFICATION OF INDEPENDENCE:

- ✓ NEMO CERT, LLC does not have, nor does it intend to acquire or will it acquire, a financial interest in any company manufacturing or distributing products it evaluates.
- ✓ NEMO CERT, LLC is not owned, operated or controlled by any company manufacturing or distributing products it evaluates.
- ✓ This is a building code evaluation. NEMO CERT, LLC is not, in any way, the Designer of Record for any project on which this NER, or previous versions thereof, is/was used for permitting or design guidance.



1. CODES, PROPERTIES AND STANDARDS:

CODE	SECTION	PROPERTY	STANDARD
2023 Florida Building Code, 8 th Edition	1523.6.5.2.13	Wind Driven Rain	TAS 100(A)
	1507.4.3	Material standard	ASTM A792

2. PRODUCTS:

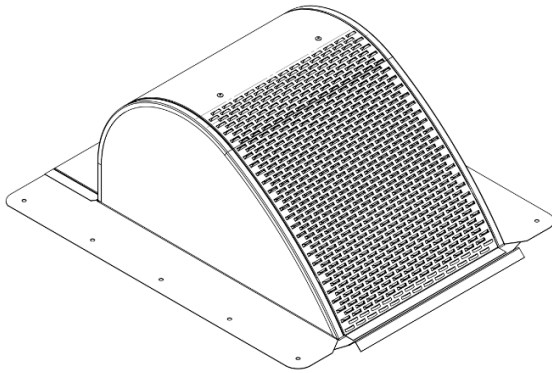
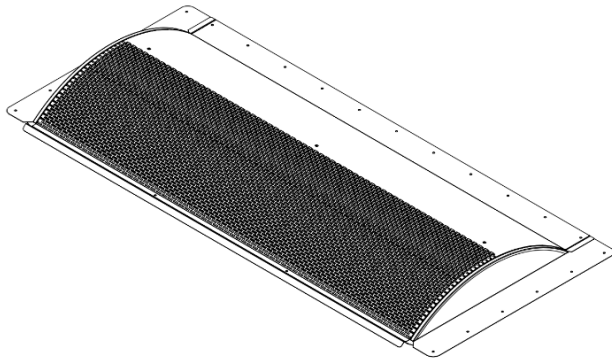
TABLE 1A: EVALUATED MARCO COMPONENTS (NEMO Certified. Consult Directory of Certified Products for production location(s))		
TRADE NAME	DESCRIPTION	PUBLISHED NFVA ¹
Shingle Gooseneck Vent	26-ga, min. 51-ksi, ASTM A792 Galvalume® steel off-ridge static roof vent, with an internal louver panel and baffle, for use with low-profile shingle roof systems. Shingle Gooseneck Vent is available in 19 ³ / ₁₆ -inch length by 4, 6 or 10-inch widths and 7 ½-inch height.	25 in ² /ft
		
Figure 1: Shingle Gooseneck Vent		
Shingle Off Ridge Vent	26-ga, min. 51-ksi, ASTM A792 Galvalume® steel off-ridge static roof vent for use with low-profile shingle roof systems. The product is available in 48-inch length by 23 ½-inch width and 3 ¼-inch height.	25 in ² /ft
		
Figure 2: Shingle Off Ridge Vent		

¹ Net Free Ventilation Area (NFVA) reported herein is as published by the manufacturer at the time of evaluation. The report user should verify current published data at the time of design and/or permitting to the satisfaction of the Authority Having Jurisdiction.

TABLE 1A: EVALUATED MARCO COMPONENTS <i>(NEMO Certified. Consult Directory of Certified Products for production location(s))</i>		
TRADE NAME	DESCRIPTION	PUBLISHED NFVA ¹
Metal and Tile Gooseneck Vent	26-ga, min. 51-ksi, ASTM A792 Galvalume® steel off-ridge static roof vent, with an internal louver panel and baffle, for use with low-profile metal and tile roof systems. The product is available in 19 ³ / ₁₆ -inch length by 4, 6 or 10-inch widths and 10 ¹ / ₄ -inch height.	25 in ² /ft
 <p>Figure 3: Metal and Tile Gooseneck Vent</p>		
Metal and Tile Off Ridge Vent	26-ga, min. 51-ksi, ASTM A792 Galvalume® steel off-ridge static roof vent for use with low-profile metal and tile roof systems. The product is available in 48-inch length by 23 ¹ / ₂ -inch width and 6-inch height.	25 in ² /ft
 <p>Figure 4: Tile Off Ridge Vent</p>		

TABLE 1A: EVALUATED MARCO COMPONENTS <i>(NEMO Certified. Consult Directory of Certified Products for production location(s))</i>		
TRADE NAME	DESCRIPTION	PUBLISHED NFVA ¹
Python™ Dryer Vent	26-ga, min. 51-ksi, ASTM A792 Galvalume® steel dryer roof vent for use with low-profile shingle roof systems. The product is available in 18 ¼-inch length by 12 5/8-inch width and 7 3/8-inch height.	12.57 in ² /ft
 <p>Figure 5: Python Dryer Vent</p>		
Python™ Tile Dryer Vent High Profile Galvalume	26-ga, min. 51-ksi, ASTM A792 Galvalume® steel dryer roof vent for use with high-profile metal and tile roof systems. The product is available in 17-inch length by 6-inch width and 10.3-inch height.	12.57 in ² /ft
 <p>Figure 6: Python Tile Dryer Vent High Profile Galvalume</p>		

TABLE 1A: EVALUATED MARCO COMPONENTS <i>(NEMO Certified. Consult Directory of Certified Products for production location(s))</i>		
TRADE NAME	DESCRIPTION	PUBLISHED NFVA ¹
Python™ Metal Roof Gooseneck	26-ga, min. 51-ksi, ASTM A792 Galvalume® steel off-ridge static roof vent for use with low-profile metal roof systems. The product is available in 16 ½-inch length by 4, 6, or 10-inch width and 9-inch height.	4-inch: 8.24 in ² /ft 6-inch: 18.56 in ² /ft 10-inch: 47.12 in ² /ft
		
Figure 7: Python Metal Roof Gooseneck		

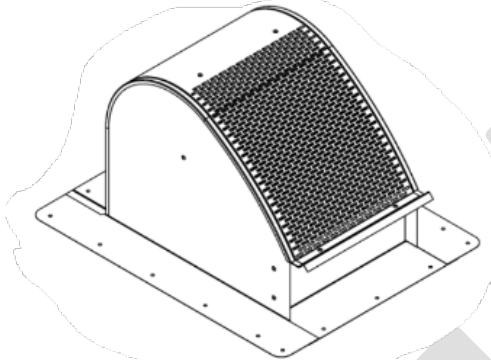
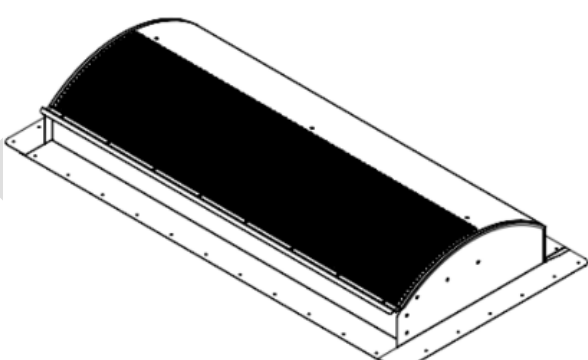

NEMO EVALUATIONS REPORT

Report No.: NER-MCI-001.R3
Revision 3: 2026-02-12
Page 6 of 7

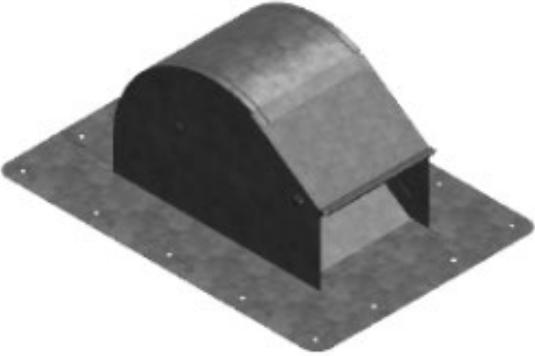
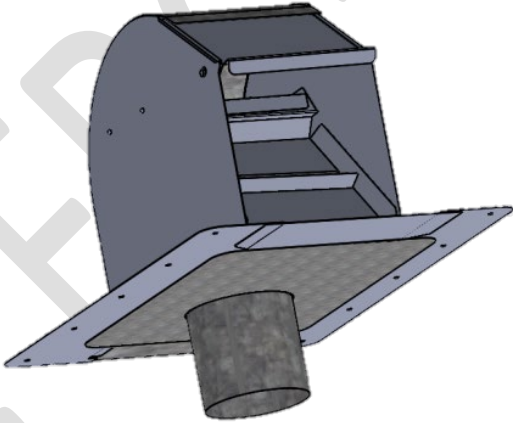
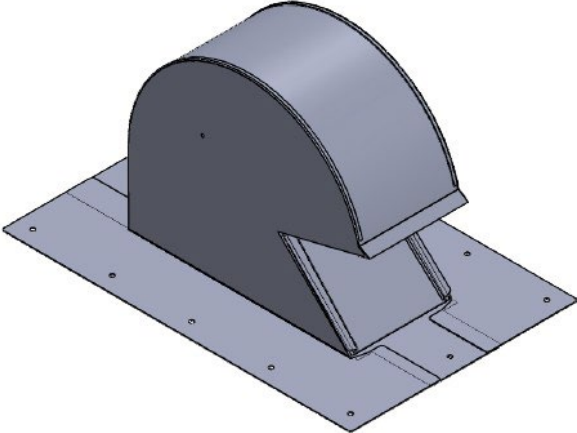
Marco Industries
FL46865-R3



3. INSTALLATION:

- 3.1 Unless otherwise noted, the term “**Marco Roof Vents**” herein includes the products reported under [Table 1A](#) of this NER.
- 3.2 **Marco Roof Vents** shall be installed in accordance with **Marco Industries’** published installation instructions, subject to the [Limitations of Use](#) noted herein.
- 3.2.1 The specifics herein pertain to attachment of the vent to the roof deck to meet wind load requirements at mean roof height less than or equal to 33 ft. Refer to **Marco Industries** published installation requirements for other important aspects of the installation.
- 3.3 **Shingle Gooseneck Vent and Shingle Off Ridge Vent:**
- 3.3.1 After locating, marking, cutting and preparing the opening in accordance with **Marco Industries’** published requirements, center vent over the opening in the deck. Leave the lower portion of the vent flashing on top of the shingles.
- 3.3.2 Shingle Gooseneck Vent: Fasten the side and top flanges to the min. 15/32-inch thick APA span rated plywood roof deck using minimum 12 ga, min. 1.25-inch long corrosion resistant roofing smooth shank nails of sufficient length to penetrate through the roof sheathing. Nails shall be spaced 4-inch o.c. and 1½-inch from the outer edge of the flange.
- 3.3.3 Shingle Off Ridge Vent: Fasten the side and top flanges to the min. 15/32-inch thick APA span rated plywood roof deck using minimum 12 ga, min. 1.25-inch long corrosion resistant roofing smooth shank nails of sufficient length to penetrate through the roof sheathing. Nails shall be spaced 4-inch o.c. and 1½-inch from the outer edge of the flange.
Fasten the bottom flange with two 1½-inch hex head #8 corrosion resistant screws with neoprene washers. Screws are to be installed at the holes located on the bottom flange.
- 3.3.4 Apply ASTM D4586 plastic roofing cement to the side and top flanges, ensuring to cover 2-inches of the underlaying substrate and seal-down any raised shingles.
- 3.4 **Metal and Tile Gooseneck Vent and Metal and Tile Off Ridge Vent:**
- 3.4.1 Locate, mark, cut and prepare the opening in accordance with **Marco Industries’** published requirements.
- 3.4.2 Fasten the side and top flanges to the min. 15/32-inch thick APA span rated plywood roof deck using minimum 12 ga, min. 1.25-inch long corrosion resistant roofing smooth shank nails of sufficient length to penetrate through the roof sheathing. Nails shall be spaced 4-inch o.c. and 1½-inch from the outer edge of the flange.
Finish by applying an approved self-adhering polymer modified bitumen underlayment complying with ASTM D1970 over the exposed flanges. The underlayment shall be installed in accordance with the underlayment manufacturer’s installation instructions.
- 3.5 **Python Dryer Vent, Python Tile Dryer Vent High Profile Galvalume, and Metal Roof Gooseneck:**
- 3.5.1 Locate, mark, cut and prepare the opening in accordance with **Marco Industries’** published requirements.
- 3.5.2 Python Dryer Vent and Python Tile Dryer Vent High Profile Galvalume: Place vent so that inner tube attaches to attic tube. Apply ASTM D4586 plastic roofing cement under the front flange of the vent, and also on top and 2-inches beyond the flange onto the underlayment. Fasten the side and top flanges to the min. 15/32-inch thick APA span rated plywood roof deck using minimum 12 ga, min. 1.25-inch long corrosion resistant roofing smooth shank nails of sufficient length to penetrate through the roof sheathing. Nails shall be spaced 4-inch o.c. through holes provided in flanges.
- 3.5.3 Python Metal Roof Gooseneck: Fasten vent flanges to the min. 15/32-inch thick APA span rated plywood roof deck using minimum 12 ga, min. 1.25-inch long corrosion resistant roofing smooth shank nails of sufficient length to penetrate through the roof sheathing. Nails shall be spaced 4-inch o.c. through holes provided in flanges.
Finish by applying an approved self-adhering polymer modified bitumen underlayment complying with ASTM D1970 over the exposed flanges. The underlayment shall be installed in accordance with the underlayment manufacturer’s installation instructions.



NEMO EVALUATIONS REPORT

Report No.: NER-MCI-001.R3
Revision 3: 2026-02-12
Page 7 of 7

Marco Industries
FL46865-R3



4. LIMITATIONS OF USE:

4.1 General:

4.1.1 This is a building code evaluation. NEMO CERT, LLC is not, in any way, the Designer of Record for any project on which this NER, or previous versions thereof, is/was used for permitting or design guidance. NERs are not to be construed as representing any attributes not specifically listed, nor are NERs to be construed as an endorsement of the subject of the report or a recommendation for its use. There is no warranty by NEMO CERT, LLC, express or implied, as to any finding or other matter in this report, or as to any product covered by the report.

4.1.2 **Shingle Gooseneck Vent, Shingle Off Ridge Vent, and Python Dryer Vent** are for use with asphalt-composition shingle roofs only.

4.1.3 **Metal and Tile Gooseneck Vent and Metal, Tile Off Ridge Vent, and Python Tile Dryer Vent High Profile Galvalume** are for use with clay or concrete tile roofs and metal panel roofs.

4.1.4 **Python Metal Roof Gooseneck** are for use with metal roofs only.

4.1.5 Installation shall result in minimum net free ventilation area requirements set forth in **FBC 1203.2**.

4.1.6 Roof Decks:

(a) This NER pertains to above-deck roof components. Roof decks and structural members shall be in accordance with FBC requirements to the satisfaction of the Authority Having Jurisdiction.

(b) OSB sheathing is not permitted in FBC HVHZ jurisdictions.

4.1.7 Slope:

(a) The minimum slope is 2:12.

(b) The maximum slope for the installation of **Marco Roof Vents** is 12:12.

4.1.8 Fire Classification:

This NER does not include evaluation of fire classification. Refer to **FBC 1505** or **FBC HVHZ 1516** for requirements and limitations regarding roof assembly fire classification.

4.1.9 Quality Assurance:

All components in the roof assembly shall have quality assurance surveillance. For Florida Product Approval, this shall be in accordance with **F.A.C. Rule 61G20-3**. For components listed herein that are produced by a manufacturer other than the report holder on [Page 1](#) of this NER, refer to the [Florida Product Approval](#) of the component manufacturer.

- END OF NER -